

Flat Panel Data Sheet

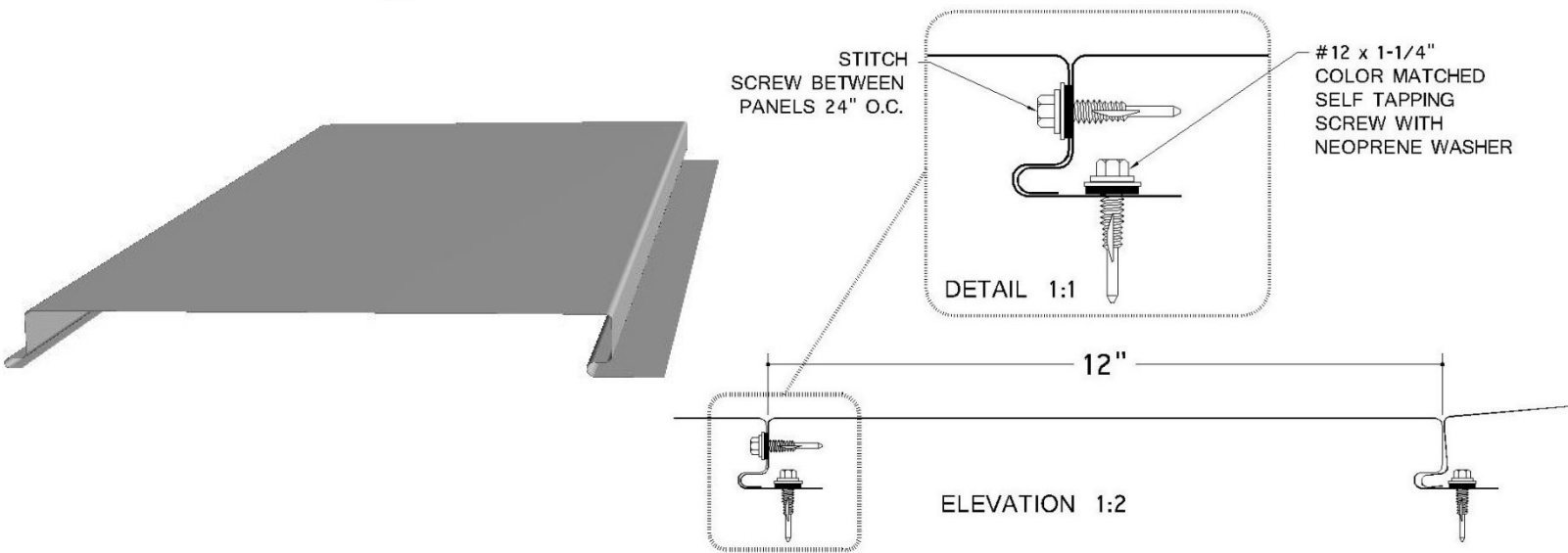

Flat and flush, this steel panel creates a wall that has no bumps or ribs. Used when you have a screen that needs to blend in with surrounding walls.

Dimensions

- 12" net coverage.
- Up to 25" long panels.
- 24 gauge standard – additional gauges are available.

Finish and Warranty

- Factory Kynar finish available in standard color.
- Paint ready zinc coating also available.
- 25 year warranty

Installation Info

- Install with seams oriented vertically.
- Anchor to frames with concealed, pan head fasteners

Additional Info

- Perforation options available.
- Stucco embossed options available

CASCADE ROOFTOP SCREENS, INC.

688 WALSH AVENUE – SANTA CLARA, CA 95050 – PHONE: (408) 827-1700

www.cascaderooftopscreens.com

CASCADE ROOFTOP SCREENS, INC.

688 WALSH AVENUE – SANTA CLARA, CA 95050 – PHONE: (408) 827-1700

www.cascaderooftopscreens.com